

DATE OF ISSUE : 2007. 02. 07

SPECIFICATION

MODEL : SLSRGBW815TS

FULL COLOR LED

CUSTOMER : _____

Preliminary

SAMSUNG ELECTRO-MECHANICS CO., LTD.

314. MAETAN3-DONG, YEONGTONG-KU,
SUWON-SI, KYUNGKI-DO, KOREA, 442-743

Contents

1. Product outline	3
2. Absolute Maximum Rating	3
3. Characteristics	3
4. Standard Ranks	4
5. Typical Characteristic Graph	5~6
6. Outline Drawing and Dimension	7
7. Reliability Test Items and Conditions	8~9
8. Solder Conditions	9
9. Taping Dimension	10
10. Reel Packing Structure	11
11. Label Structure	12
12. Precaution for Use	13
13. Hazard Substance Analysis	14~15
14. Revision History	16

Product Outline

1) Feature

1. Lead Frame Type LED Package (5.2 * 6.0 * t 1.3mm)
2. Beam Angle (: 120 °)
3. AlGaInP, GaN/Al₂O₃ Chip & Long Time Reliability

2) Applications

- . Indoor, Outdoor Display and etc.

Absolute Maximum Rating

Item	Symbol	Absolute Maximum Rating			Unit
		Red	Green	Blue	
Forward Current	I _F	30	30	30	mA
Pulse Forward Current	I _{FP}	100	100	100	mA
Reverse Voltage	V _r	5	-	-	V
Reverse Current	I _R	-	5	5	mA
Operating Temperature	T _{opr}	-30 ~ 85			°C
Storage Temperature Range	T _{stg}	-40 ~ 100			°C

- . I_{FP} Conditions : Duty 1/10 Pulse Width 10msec

Characteristics

(Ta : 25°C)

Item	Symbol	Condition	Color	min.	typ.	MAX.	Unit
Forward Voltage*	V _F	I _F = 20 mA	Red	-	2.1	2.6	V
			Green	-	3.1	3.7	
			Blue	-	3.1	3.6	
Reverse Current	I _R	V _R = 5V	R	-	-	100	μA
Reverse Voltage	V _r	I _R = 5mA	G, B	0.5	1.0	1.5	V
Luminous Intensity*	I _V	I _F = 20 mA	Red	400	550	-	mcd
			Green	1000	1500	-	
			Blue	200	350	-	
Dominant Wavelength*	λ _D	I _F = 20 mA	Red	618	-	630	nm
			Green	520	-	535	nm
			Blue	460	-	472	nm

* Tolerance : V_F ; ±0.1V, I_V ; ±10%, λ_D ; ±2nm

* Luminous intensity measuring equipment : CAS140 B

Typical Characteristics Graph

* These graphs show typical values.

(Ta : 25°C)

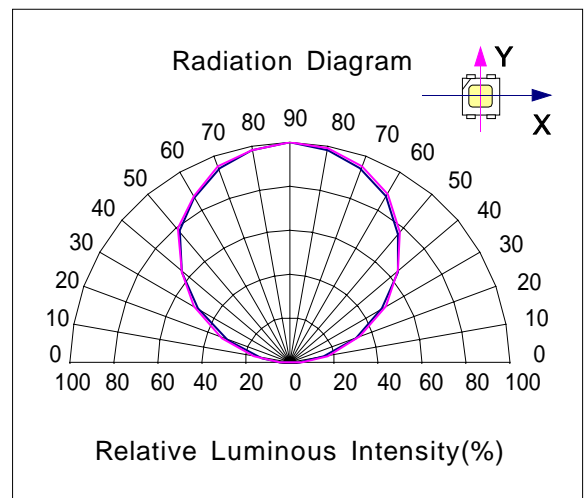
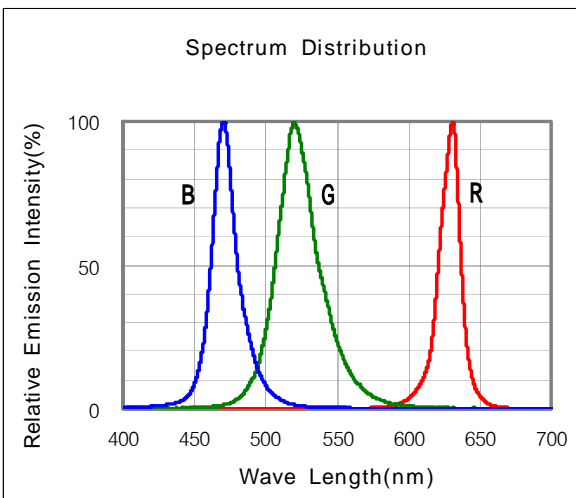
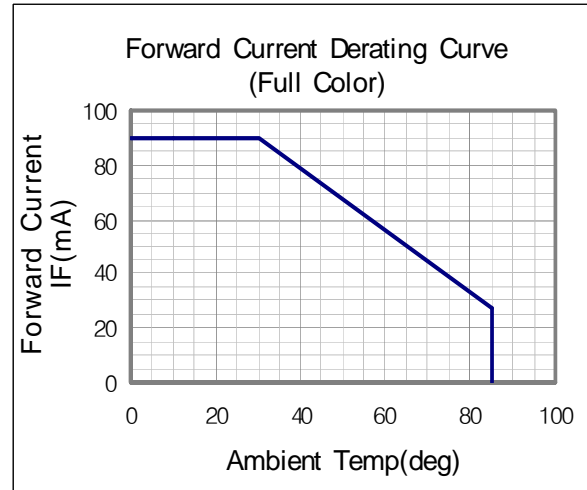
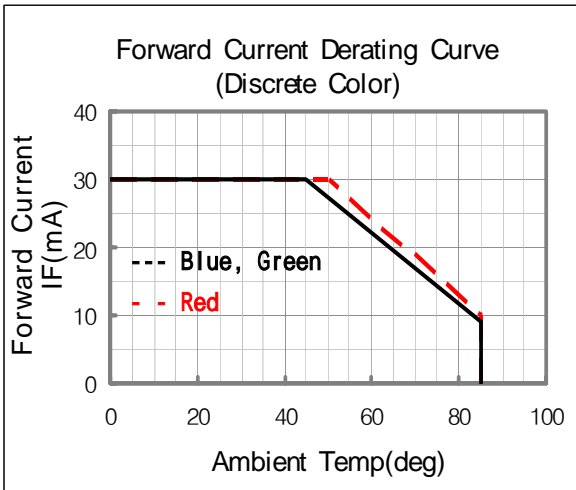
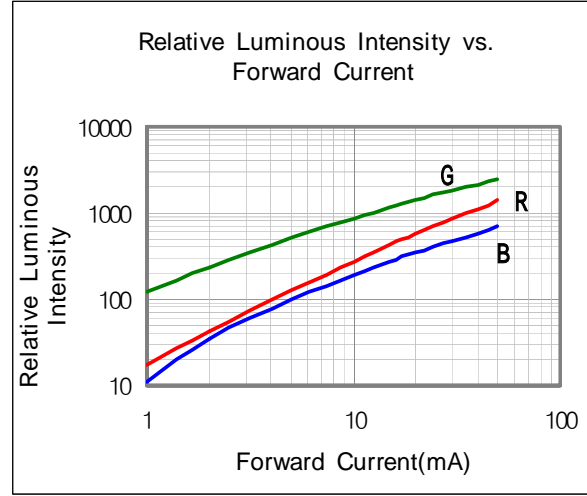
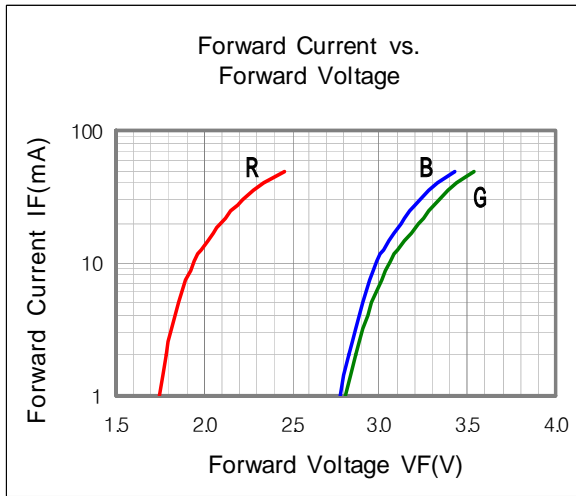

LED Package Outline Dimensions

unit:mm

Tolerance: ±0.1

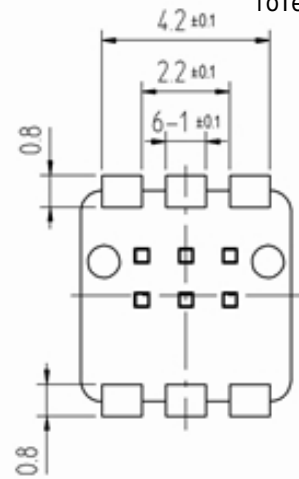
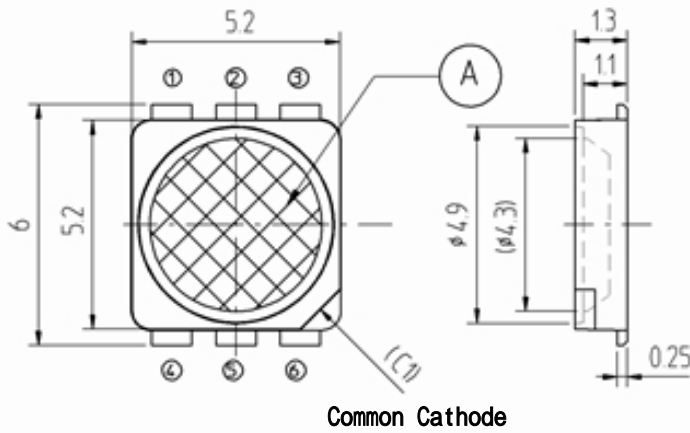

Tolerance is ±0.2mm unless otherwise noted.
The maximum compressing pressure is 15N.
Do not apply any damage on the phosphor ('A').

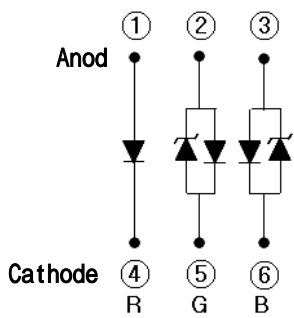

Circuit Diagram

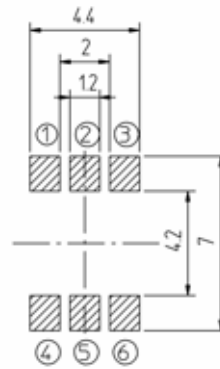

Pattern

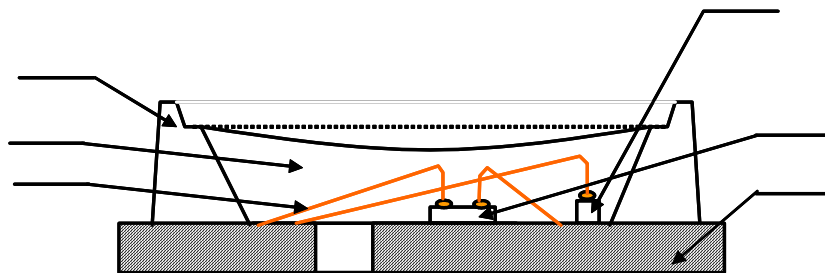

NUMBER	ITEM	MATERIAL
	FRAME	Copper Frame(Silver Plated)
	LED CHIP	AlGaInP, GaN/Al ₂ O ₃
	Zener Diode	Si
	WIRE	Gold Wire
	RESIN	Resin
	PACKAGE	Heat-resistant Polymer

Reliability Test Items and Conditions

1) Test Items and Results

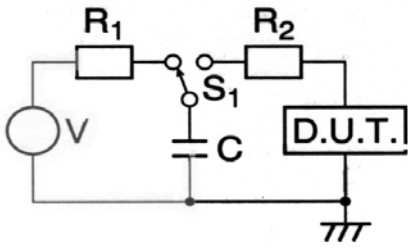
Test Item	Test Conditions	Test Hours/Cycles	Sample No
Room Temperature life test	25 ±3 , Red;DC30 mA, Green;DC30 mA, Blue;DC30 mA	500 h	50
High Temperature humidity life test	60 ±3 , 95%±2%RH, Red;DC18 mA, Green;DC18 mA, Blue;DC18 mA	500 h	50
High Temperature life test	85 ±3 , Red;DC9 mA, Green;DC9 mA, Blue;DC9 mA	500 h	50
Low Temperature life test	-30 ±3 , Red;DC30 mA, Green;DC30 mA, Blue;DC30 mA	500 h	50
High Temperature humidity Storage	60 ±3 , 95%±2%RH	500 h	22
High Temperature Storage	Ta=100 ±3	500 h	22
Low Temperature Storage	Ta= -40 ±3	500 h	22
Thermal Shock	-40 ~ 100 0.5 h 0.5 h	100 cycles	50
Temperature humidity Cycle	25 ~ 65 ~ -10 24hrs/1cycle, 95%RH	10 cycles	22
Reflow Soldeing (Pb-Free)	Peak 260±5 for 10sec, 220 over time 60sec max	3 times	22
ESD(HBM)	 <p>-R1:10M , R2:1.5K , C:100pF</p>	5 times (±2KV)	5
On/Off test	50 ±3 , 95%±2%RH, On/2sec, Off/2sec Red;DC30 mA, Green;DC30 mA, Blue;DC30 mA	120h	50

2) Criteria for Judging the Damage

Item	Symbol	Test Condition	Limit	
			Min	Max
Forward Voltage	V_F	$I_F=20 \text{ mA}$	-	U.S.L.*1.2
Luminous Intensity	IV	$I_F=20 \text{ mA}$	L.S.L.*0.5	-
Reverse Current	I_R	$V_R=5V$	-	U.S.L.*2.0
Reverse Voltage	V_R	$I_F=5 \text{ mA}$	L.S.L.*1.2	U.S.L.*1.2

* USL : Upper Standard Level LSL : Lower Standard Level

Solder Conditions

1) Reflow Conditions (Pb Free)

Reflow Frequency : 2 times max.

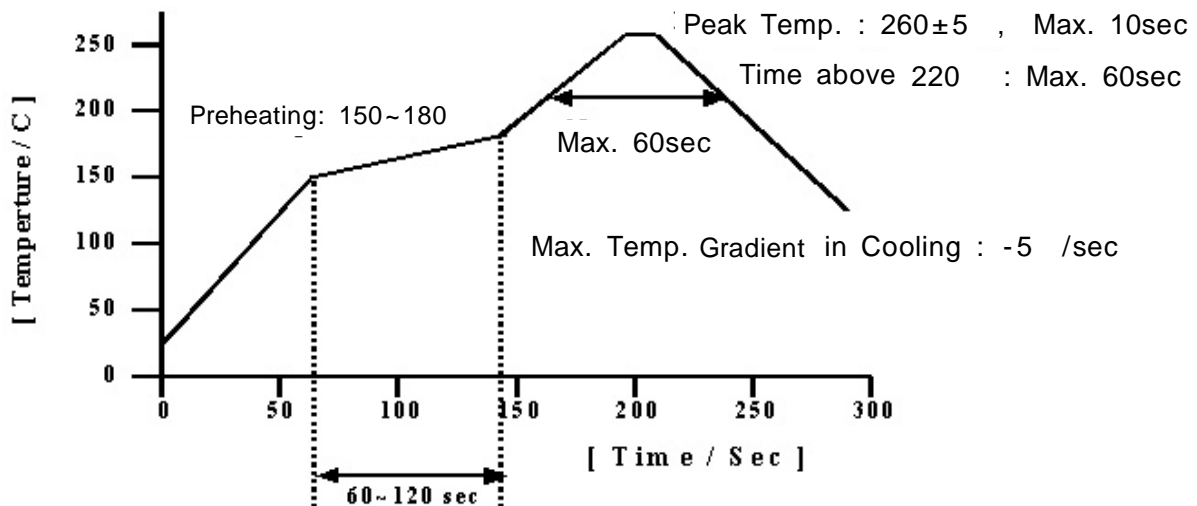

2) For Manual Soldering

Not more than 5 seconds @MAX300 , under soldering iron.(one time only)

Taping Dimension

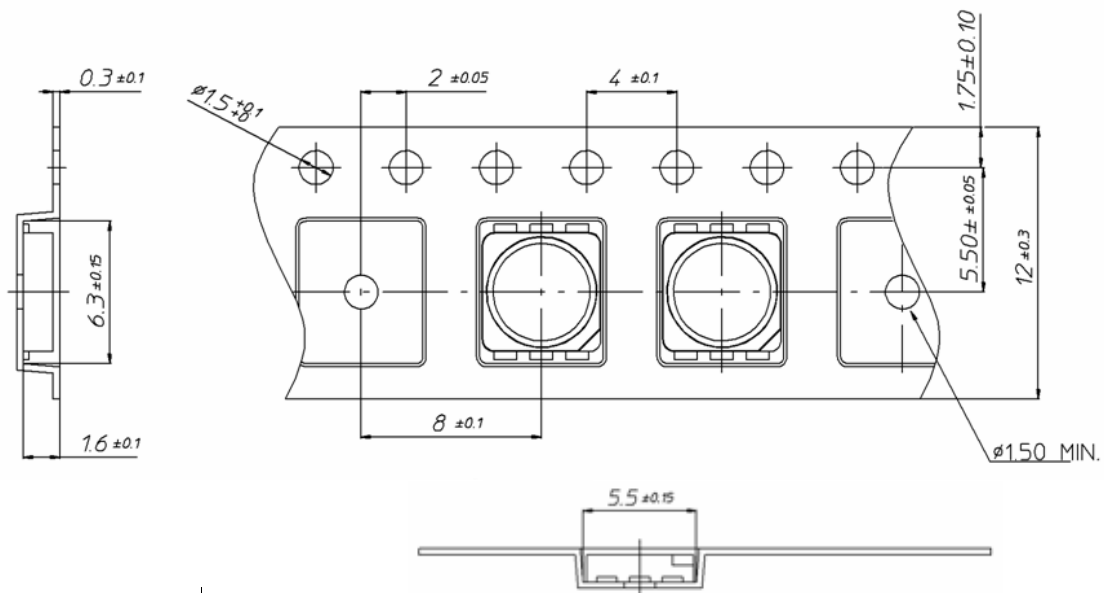

More than 40 mm
Unloaded tape

Mounted with
Flash LED

More than (100~200)mm
Unloaded tape

Leading part more than
(200~400)mm

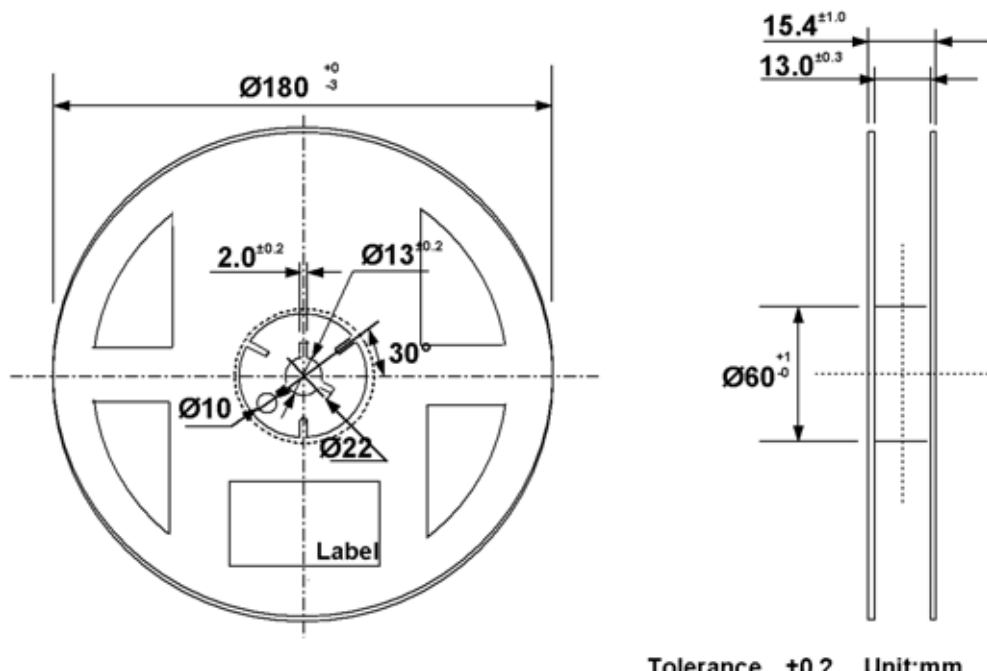

Tolerance +0.2 Unit:mm

- (1) Quantity : The quantity/reel to be 1000pcs.
- (2) Cumulative Tolerance : Cumulative tolerance/10 pitches to be ± 0.2 mm
- (3) Adhesion Strength of Cover Tape : Adhesion strength to be 0.1-0.7N when the cover tape is turned off from the carrier tape at 10° angle to be the carrier tape.
- (4) Packaging : P/N, Manufacturing data code no. and quantity to be indicated on a damp proof package.

Reel Packing Structure

Reel

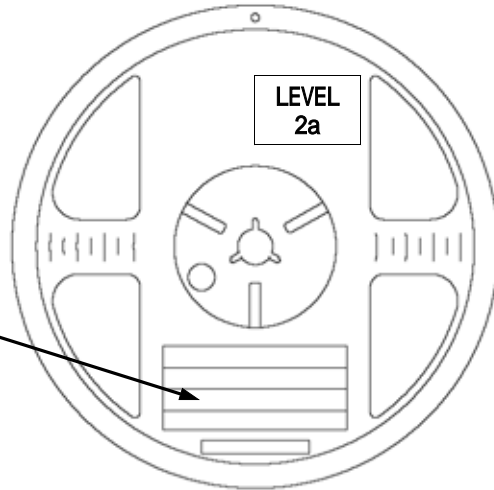
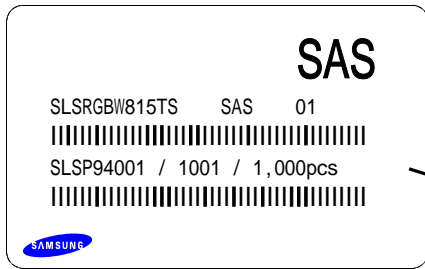

Aluminum Vinyl Bag

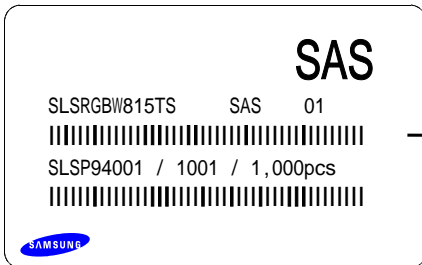

Material : Paper(SW3B(B))

Unit:mm

Tolerance: ±7

TYPE	SIZE(mm)		
7inch	245	220	182

SIDE

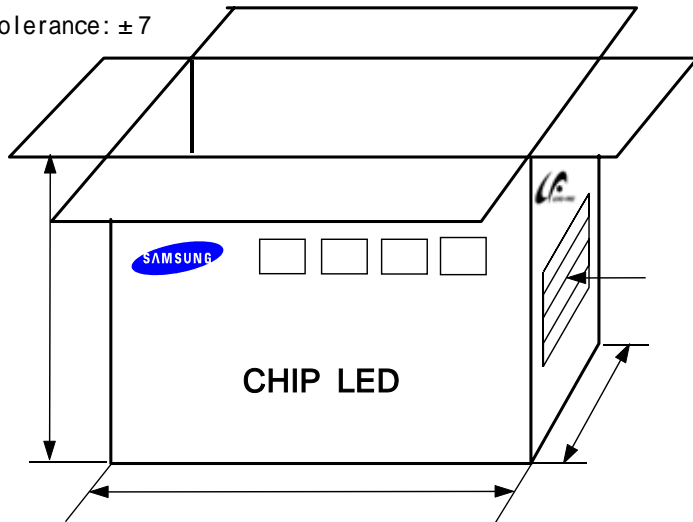
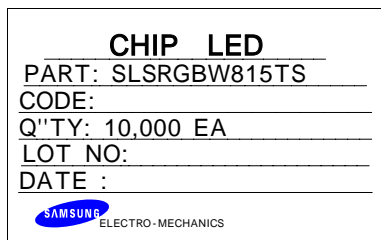

Label Structure

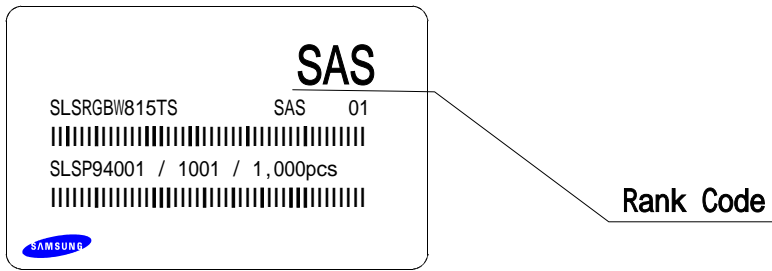

Rank Code

- : VF Rank
- : Wavelength
- : IV Rank

Precaution for use

1. This device should not be used in any type of fluid such as water, oil, organic solvent, etc.
When washing is required, IPA should be used.
2. When the LEDs are illuminating, operating current should be decided after considering the ambient maximum temperature.
3. LEDs must be stored to maintain a clean atmosphere.
If the LEDs are stored for 3 months or more after being shipped from Samsung Electro-Mechanics, a sealed container with a nitrogen atmosphere should be used for storage.
4. The LEDs must be used within seven days after opening the moisture proof packing. Repack unused Products with anti-moisture packing, fold to close any opening and then store in a dry place.
5. The appearance and specifications of the product may be modified for improvement without notice.
6. This LEDs is sensitive to the static electricity and surge. It is recommended to use a wrist band or anti-electrostatic glove when handling the LEDs.

If over voltage which exceeds the absolute maximum rating is applied to LEDs, it will cause damage LEDs and result in destruction.

Damaged LEDs will show some unusual characteristics such as leak current remarkably increase, turn-on voltage becomes lower and the LEDs get unlighted at low current.

