

Cree® XLamp® XR-E Blue LED

Data Sheet

Cree XLamp LEDs combine the brightness of power LED chips with a rugged package capable of operating in excess of three watts. Cree XLamp LEDs lead the solid-state lighting industry in brightness while providing a reflow-solderable design that is optimized for ease of use and thermal management. Lighting applications featuring XLamp LEDs maximize light output and increase design flexibility, while minimizing environmental impact.

Cree XLamp LEDs bring industry-leading brightness to a wide range of lighting and backlighting applications, including portable lighting and flashlights, outdoor and industrial, signaling, architectural, landscaping and entertainment/advertising installations.

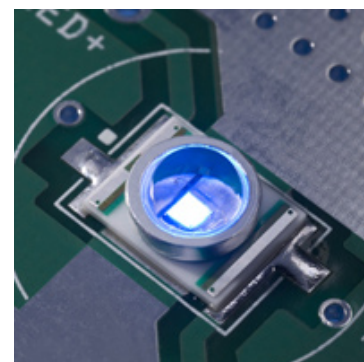

FEATURES

- Full range of drive currents up to 700 mA
- Surface-mount technology — reflow solderable
- Low operating voltage
- Electrically neutral thermal path
- RoHS-compliant — lead-free
- Integrated glass lens
- Small footprint — 7.0 mm x 9.0 mm
- ESD > 2000 V
- Lumen maintenance of greater than 70% on average after 50,000 hours

Table of Contents

Flux Characteristics.....	2
Characteristics	2
Relative Spectral Power	3
Photometric Output vs. Junction Temperature ($I_f = 350$ mA).....	3
Electrical Characteristics ($T_j = 25^\circ\text{C}$).....	4
Relative Intensity vs. Current ($T_j = 25^\circ\text{C}$).....	4
Typical Spatial Radiation Pattern	5
Thermal Design	5
Reflow Soldering Characteristics	6
Environmental Compliance / RoHS / Vision Advisory Claim	7
Mechanical Dimensions	8
Tape and Reel	9
Dry Packaging and Packaging	10

Flux Characteristics

Color	Dominant Wavelength (nm)	
	Min.	Max.
Royal Blue	450	465
Blue	465	485

Cree maintains a tolerance of +/- 7% on flux and power measurements.

Characteristics

Characteristics	Unit	Minimum	Typical	Maximum
Thermal Resistance, junction to solder point	°C/W		8	
Full-Width Half-Maximum	degrees		90	
Temperature coefficient of voltage	mV/°C		-2.8	
ESD Classification (HBM per Mil-Std-883D)			Class 2	
DC Forward Current	mA			700
DC Pulse Current (@ 1 kHz, 10% duty cycle)	A			1.8
Reverse Voltage	V			5
Forward Voltage (@ 350 mA)	V		3.3	3.9
Forward Voltage (@ 700 mA)	V		3.5	
LED Junction Temperature	°C			145
Operating Temperature	°C	-40		85

Relative Spectral Power

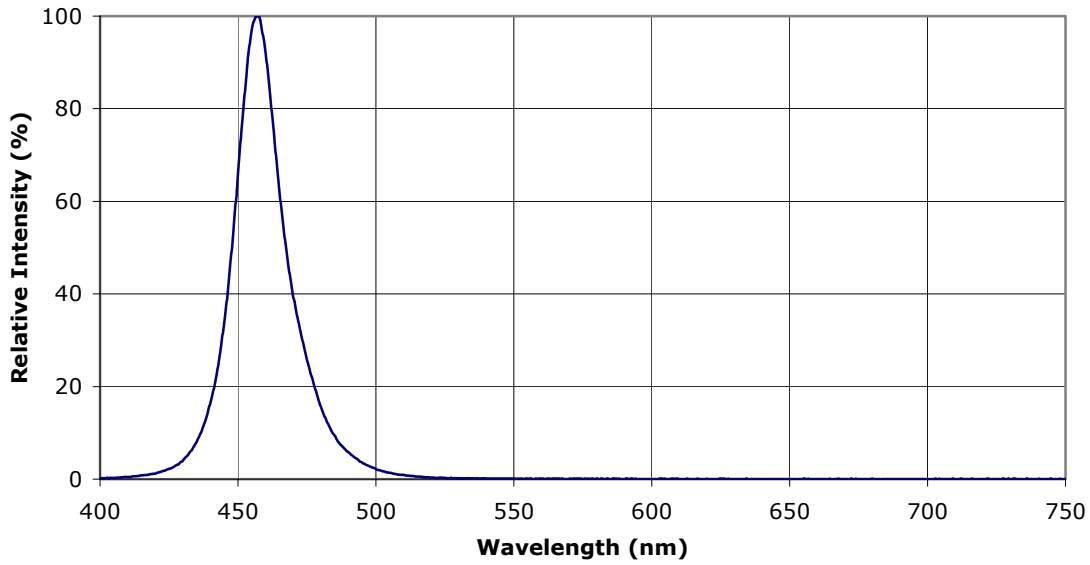

Photometric Output vs. Junction Temperature ($I_f = 350$ mA)

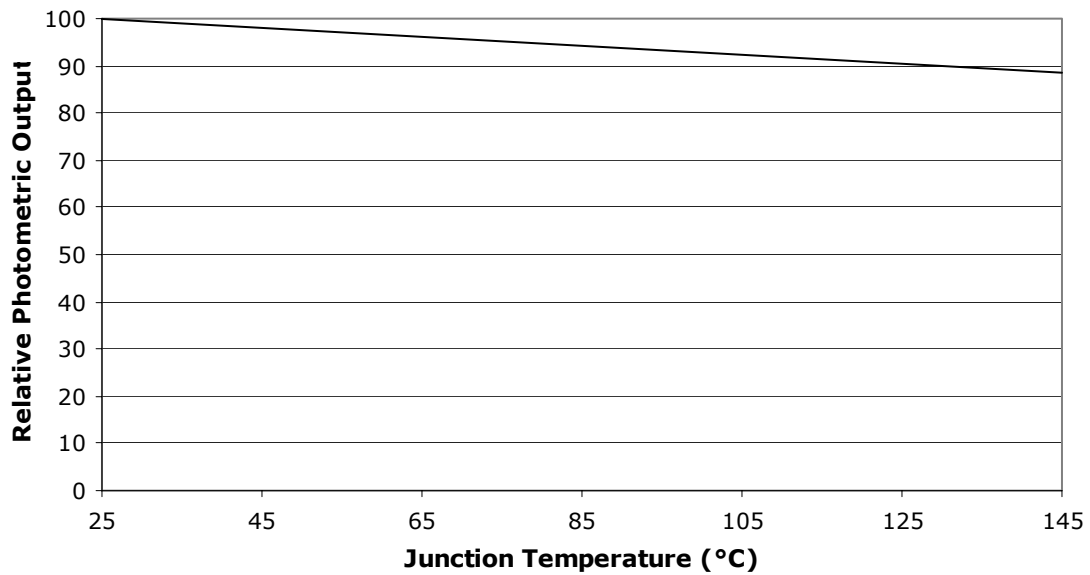

Electrical Characteristics ($T_j = 25^\circ\text{C}$)

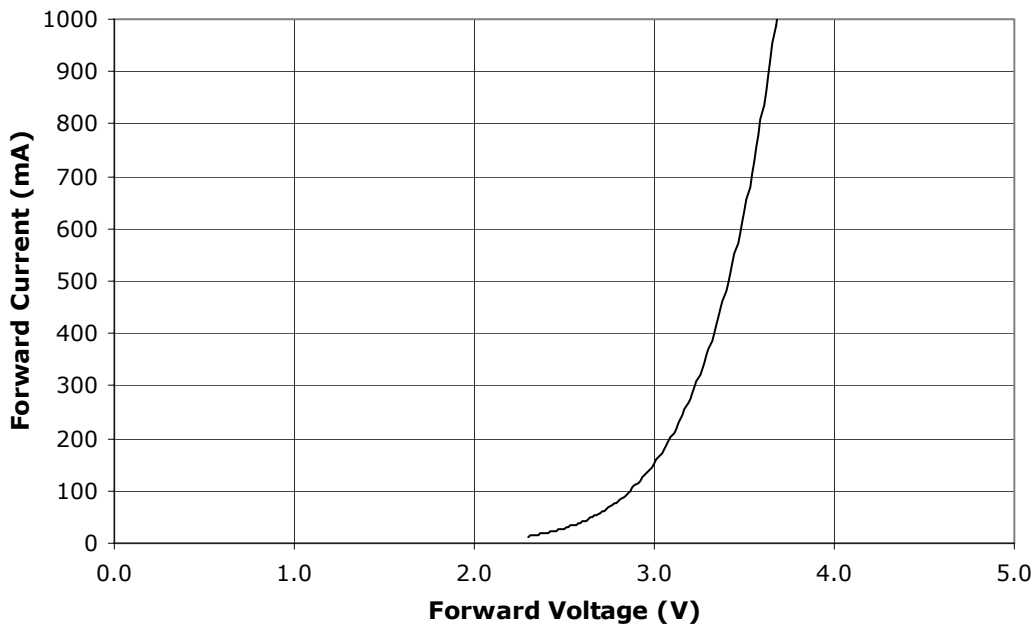

Relative Intensity vs. Current ($T_j = 25^\circ\text{C}$)

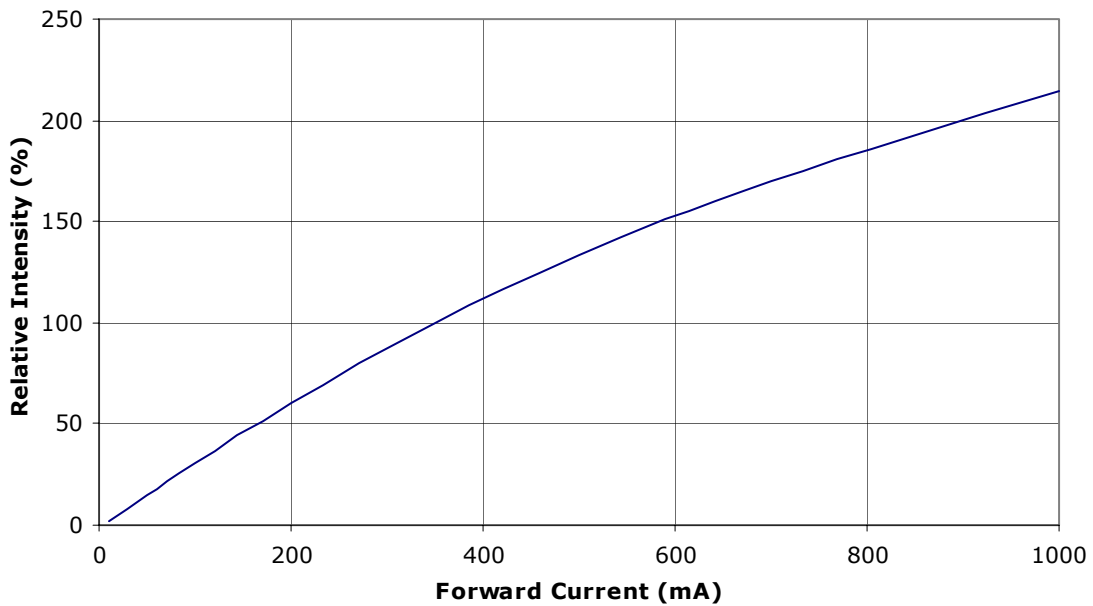

Typical Spatial Radiation Pattern

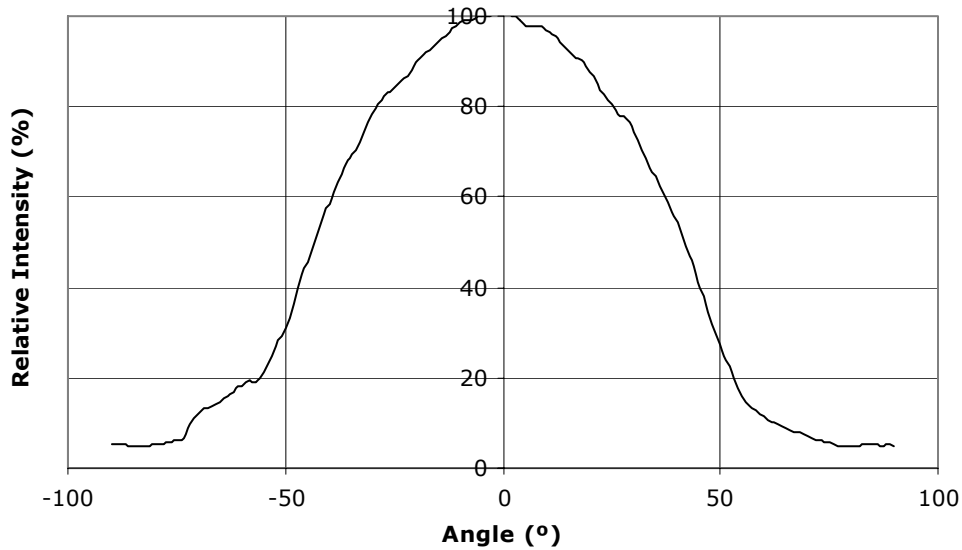

Thermal Design

The maximum forward current is determined by the thermal resistance between the LED junction and ambient. Given an existing thermal resistance of 8°C/W between the junction and the solder point, it is crucial for the end product to be designed in a manner that minimizes the thermal resistance from the solder point to ambient in order to optimize lamp life and optical characteristics.

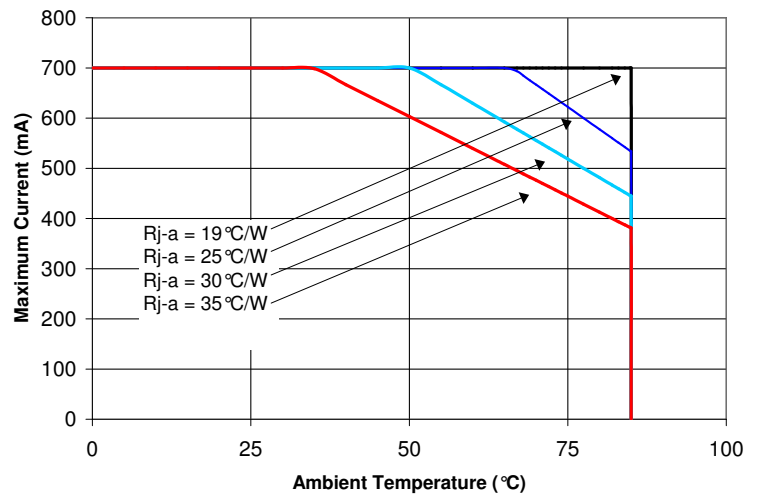

Reflow Soldering Characteristics

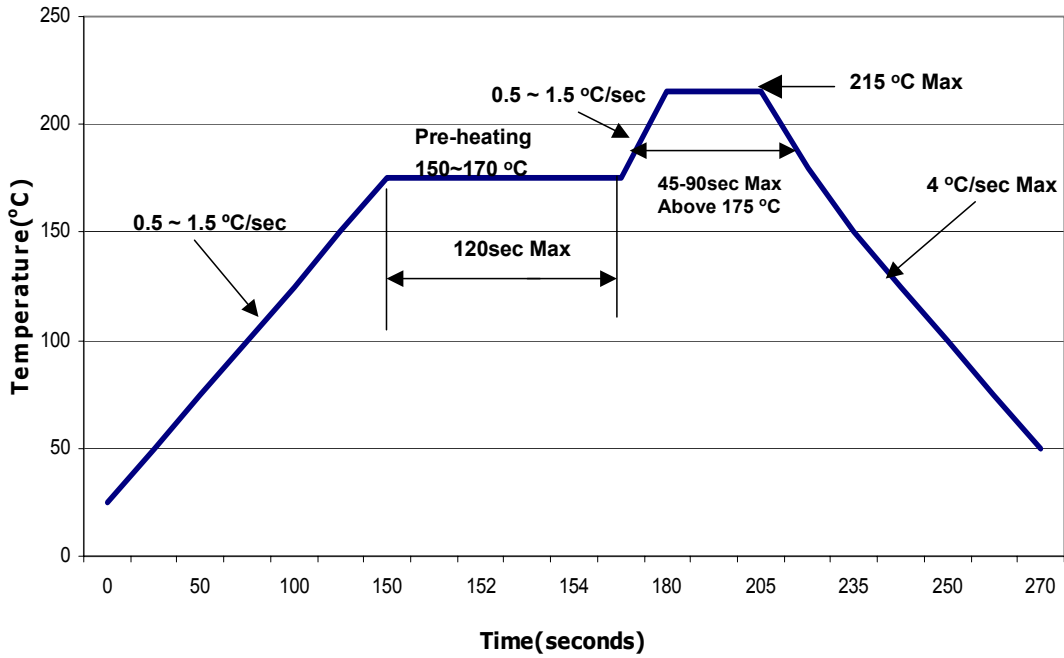

Lead-Based Solder Profile

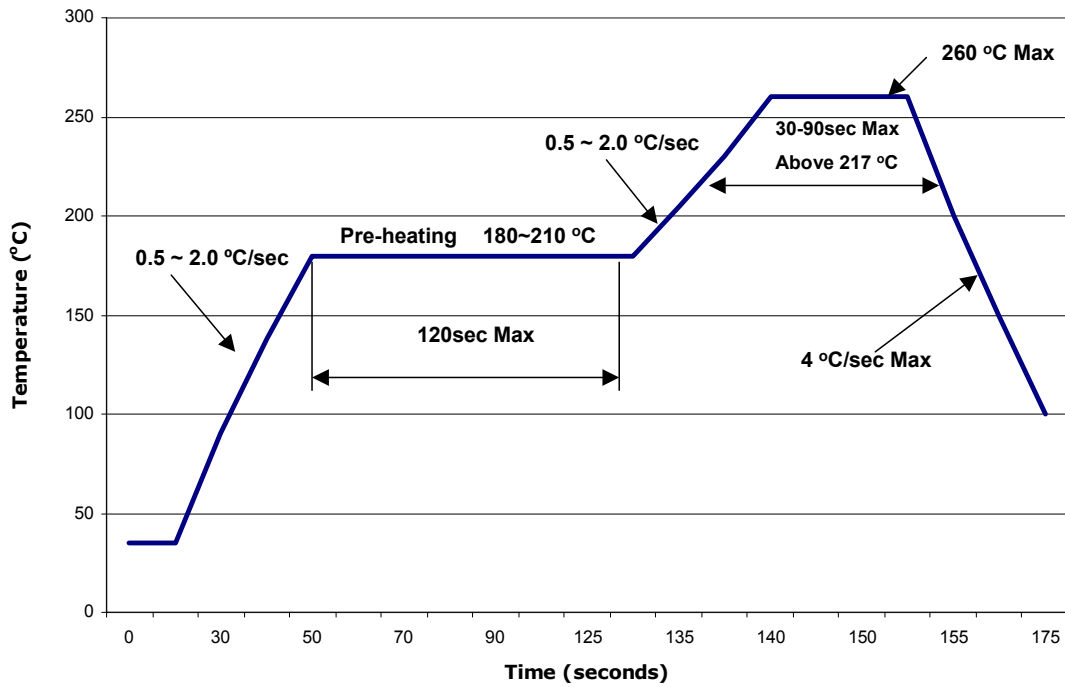

Lead-Free Solder Profile

Notes

Lumen Maintenance Projections

Based on internal long-term reliability testing and standardized forecasting methods, Cree projects XLamp LEDs to maintain an average of 70% lumen maintenance after 50,000 hours, provided the LED junction temperature is maintained at or below 80 °C.

Please read the XLamp Reliability application note for more details on Cree's lumen maintenance testing and forecasting. Please read the XLamp Thermal Management application note for details on how thermal design, ambient temperature, and drive current affect the LED junction temperature.

Moisture Sensitivity

If XLamp LEDs are exposed to excessively moist environments before soldering, damage to the LED may occur during the soldering operation. Specifically, XLamp LEDs exposed to factory ambient conditions exceeding 30°C / 60% RH at any time or less than 30°C / 60% RH for greater than 72 hours (not counting time in proper storage) must be baked at 80°C for 24 hours to avoid damage during reflow soldering. Within one hour of baking or one hour of opening the original packaging, XLamp LEDs must be stored according to Section 5.3 (Safe Storage) of JEDEC J-STD-33. Otherwise, these parts must be baked again at 80°C for 24 hours and resealed properly within one hour of baking. Do not bake parts at temperatures higher than 80°C, as damage to the reel will occur.

RoHS Compliance

The levels of environmentally sensitive, persistent biologically toxic (PBT), persistent organic pollutants (POP), or otherwise restricted materials in this product are below the maximum concentration values (also referred to as the threshold limits) permitted for such substances, or are used in an exempted application, in accordance with EU Directive 2002/95/EC on the restriction of the use of certain hazardous substances in electrical and electronic equipment (RoHS), as amended through April 21, 2006.

Vision Advisory Claim

Do not stare directly into the light beam of this Cree product. The bright light can damage the eye.

Mechanical Dimensions

All measurements are ± 0.1 mm unless otherwise indicated.

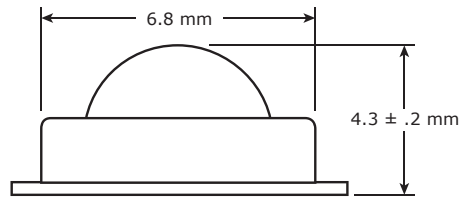
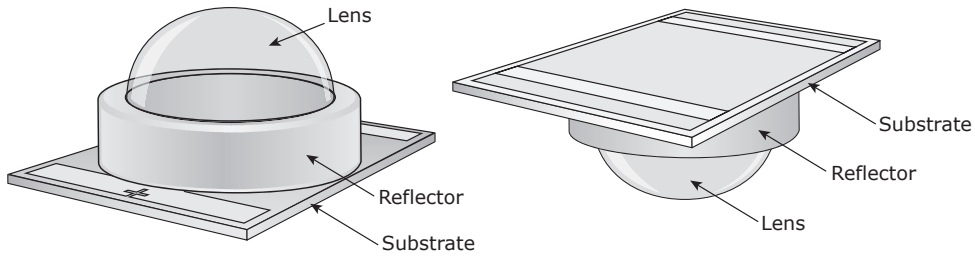

Side View

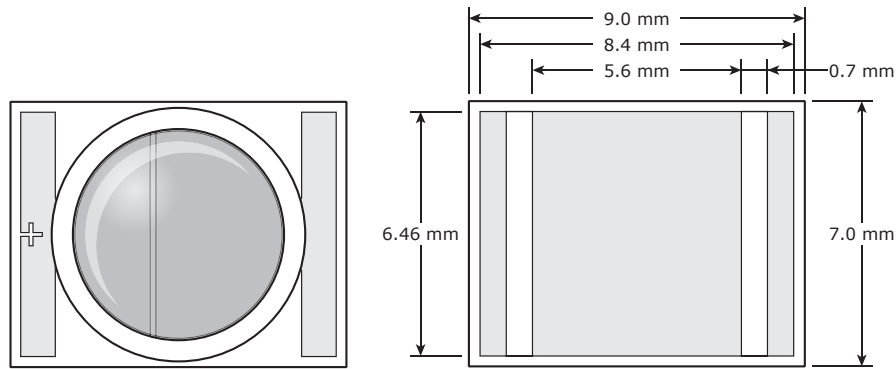

Top View

Bottom View

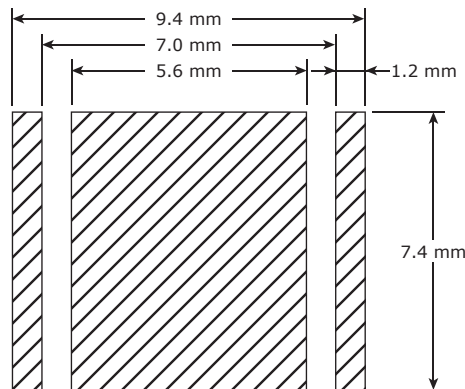

Recommended PC Board Solder Pad

Tape and Reel

All dimensions in mm.

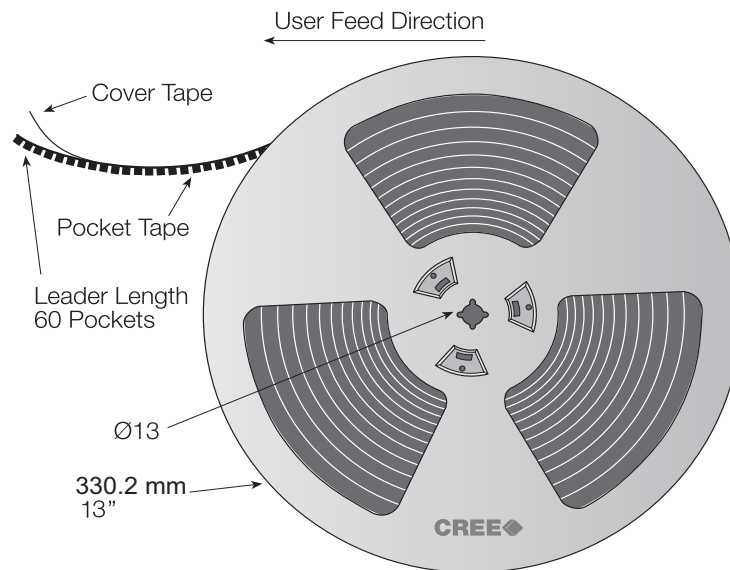
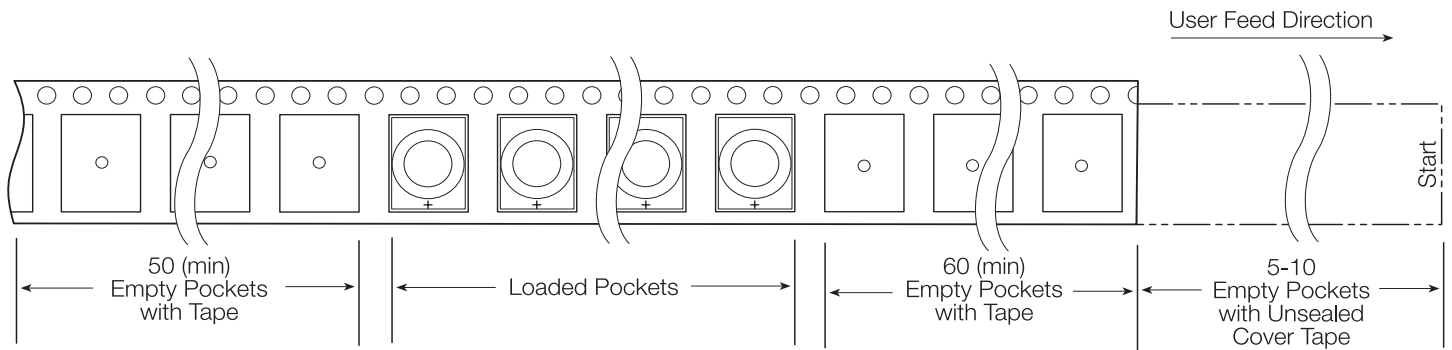
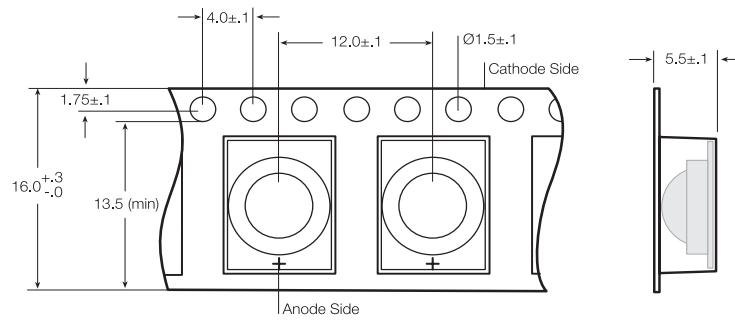

Dry Packaging and Packaging

